

Astra Tech Implant System®

Screw-retained restorations

Clinical and laboratory procedures
OsseoSpeed® TX

Astra Tech Implant System®

CONTENTS

Clinical and laboratory procedures for screw-retained restorations utilizing Astra Tech Implant System®.

Introduction	2
Contents	3
Restorative overview	4
Restorative options for screw-retained restorations	5
Treatment planning	6
Considerations and implant overview	7
Healing Abutment Uni	8
Abutment selection	10
UniAbutment	12
Angled Abutment	13
Healing Cap	14
Abutment-level impression	16
Abutment-level working model	18
Cylinder options	23
Care and maintenance	28
Abutment removal	29
Torque guide	31
Miscellaneous	
Sterile packaging	32
References	33

This manual is designed for use by clinicians who have undergone at least basic prosthetic and in-clinic implant training. Staying current on the latest trends and treatment techniques in implant dentistry through continued education is the responsibility of the clinician.

To improve readability for our customers, Dentsply Sirona does not use ® or ™ in body copy. However, Dentsply Sirona does not waive any right to the trademark and nothing herein shall be interpreted to the contrary.

Restorative overview

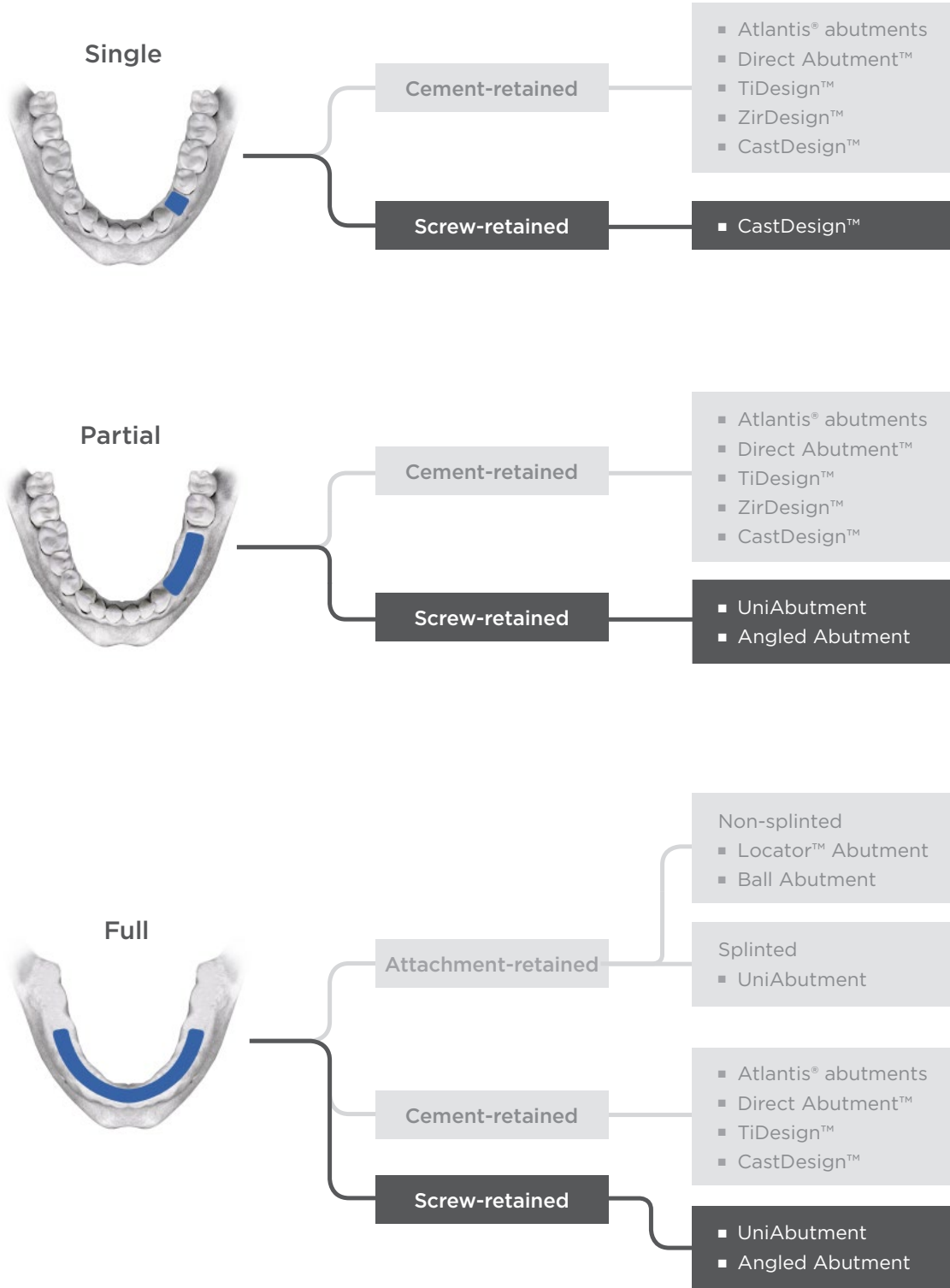

Conventional technique using the Astra Tech Implant System®

When working with implant restorations treatment planning, teamwork and product selection are crucial to long-term esthetic results. It is also important to carefully follow the restorative handling procedures.

In this manual you will find the clinical and laboratory procedures using conventional technique for screw-retained restorations with Astra Tech Implant System.



Customized abutments for screw-retained restorations

The CastDesign is a non-oxidizing high precious abutment designed and manufactured at the laboratory. CastDesign is for fabrication of a customized abutment for cement-retained restorations, using regular wax-up and cast-to techniques.

Note: In cases where high biteforces are expected it is recommended to select a titanium abutment if possible. CastDesign should primarily be regarded as an abutment used when no titanium option is available.

For screw-retained restoration, CastDesign shall be used for single-tooth applications only. Use of this product outside the listed indications will compromise the function of the Conical Seal Design and void the Dentsply Sirona Implant warranty.

For customized abutment handling procedures, see the Cement-retained restoration manual.



Treatment planning

To achieve the desired outcome of the restorative treatment, it is essential to develop a careful treatment plan. This should be based on a thorough analysis of morphology, function, hygiene and esthetics.

The final prosthetic result is, to a great extent, a function of how well the implants are positioned. Radiographs and models on an articulator should be studied by the surgical and restorative dentist at an early stage of the treatment. The optimal location and inclination of each individual implant should be registered.

An esthetic wax-up offers an idea about the teeth in relation to the ridge, as well as to each other.

From the wax-up, an acrylic stent can be made for use during surgery, where it can be used as a helpful guide of implant position and inclination.

The final evaluation regarding implant placement is done during surgery, when there is access to the exposed jawbone.

Before starting the restorative treatment, make sure that the following conditions are met:

- The patient must be free of any symptoms from the implant and the healing abutment installation procedures
- The gingiva around each healing abutment must be in healthy condition or be in the process of healing without complications
- The healing abutments should be checked for accuracy of length and good fixation in the implants
- The clinical examination must not give any indications of failed osseointegration, i.e., mobility, tenderness or signs of inflammation
- The patient must be informed about the restorative treatment and the expected outcome



Models on an articulator should be studied at an early stage of the treatment. An acrylic stent can be made for use during surgery, where it can be used as a helpful guide of implant position and inclination.



A stent in use during surgery. The final evaluation regarding implant placement is done during surgery when there is access to the exposed jawbone.



A wax-up offers an idea about the teeth in relation to the ridge, as well as to each other.



The teeth set-up in wax is tried out in the mouth and minor adjustments are made.

Implant overview

The OsseoSpeed TX implants have been developed and extensively documented for both one- and two-stage surgical procedures. The Conical Seal Design of the Astra Tech Implant System allows for a strong and stable implant-abutment connection.







Intended use

- In replacing missing teeth in single or multiple unit applications within the mandible or maxilla
- Indicated for immediate placement in extraction sites and partially or completely healed alveolar ridge situations
- Especially indicated for use in soft bone applications where implants with other implant surface treatments may be less effective
- Suitable for immediate loading* in all indications, except in single tooth situations in soft bone (type IV) where implant stability may be difficult to obtain and immediate loading may not be appropriate

*Immediate loading of single-tooth restorations with OsseoSpeed TX Implant 4.0 S - 6 mm is not recommended.

It is important that the clinician takes loading conditions into consideration when determining the number and spacing of short implants. Considering the reduced bone support provided by short implants, it is important for the purpose of early diagnosis and treatment that the clinician closely monitor soft tissue and supporting bone health status by means of probing and radiographic evaluation when indicated.

From a mechanical strength point of view it is recommended to always place as wide an implant as possible. This is particularly important in the posterior regions of the jaws where loading forces are high and considerable bending moments could be generated.

OsseoSpeed® TX Implant	<p>3.0 S</p>  <p>3.0 mm 1.7 mm</p>	<p>3.5 S</p>  <p>3.5 mm 1.9 mm</p>	<p>4.0 S</p>  <p>4.0 mm 2.4 mm</p>	<p>4.5</p>  <p>4.5 mm 1.9 mm</p>	<p>5.0</p>  <p>5.0 mm 2.4 mm</p>	<p>5.0 S</p>  <p>5.0 mm 3.2 mm</p>
Indications	For replacement of maxillary laterals and mandibular central and lateral incisors when there is not enough space for a wider implant.	In all positions in the jaws. Single tooth to full arch.	In all positions in the jaws. Single tooth to full arch.	In all positions in the jaws. Single tooth to full arch.	In all positions in the jaws. Single tooth to full arch.	In all positions in the jaws. Especially indicated for wide edentulous spaces and for increased stability in extraction sockets when doing immediate implant installation. Single tooth to full arch.
Note	It is recommended that when possible, a wider implant is used.	For single-standing, non-splinted restorations in the molar regions, the use of a wider implant is recommended.	OsseoSpeed TX Implant 4.0 S - 6 mm should only be used when there is not enough space for a longer implant. Immediate loading of single tooth restorations is not recommended.			

Healing Abutment

Healing Abutment Uni is a solid one-piece component, designed to provide optimal esthetic results.

The abutment is used for soft tissue contouring during the soft-tissue healing phase and can be used for both one and two-stage surgery.

The implant system should not dictate when to use a one or a two-stage surgical approach. It should be up to you and the particular clinical requirements. Even with adequate planning, situations may occur that demand a change of procedure. Astra Tech Implant System provides optimal solutions for both one and two-stage surgery. The system allows intra-operative changes using the same components with the same predictable results.

Clinical application

- All positions in the mouth
- For intermediate use only

Features and benefits

- Soft tissue management
- Documented biocompatibility
- Laser-etched bands for measuring the mucosal height over the implant level in millimeters
- Easy selection of a suitable Healing Abutment Uni
- Different heights for maximized flexibility
- Friction fit to the Hex Screwdriver for easy handling

Clinical procedure – Healing Abutment Uni

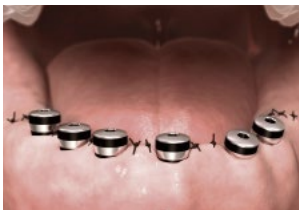

One-stage surgery

Healing Abutment Uni is placed at the implant installation.

After healing, the abutment is replaced by a permanent abutment.

Two-stage surgery

A cover screw is connected to the implant at implant installation.

Reposition the mucoperiosteal flaps carefully and suture tightly together until it is time to replace the cover screw with a Healing Abutment Uni or a final abutment.

Seating and tightening

The Healing Abutment Uni is seated in the implant, secured and tightened using the Hex Screwdriver and light finger force or the Torque Wrench. Recommended torque is 5-10 Ncm.



Abutment selection
 Diameter 4 mm
 Heights above implant level
 2-10 mm
 Sterile

Material
 Titanium



Healing Abutment Uni is available for connection size - 3.5/4.0 and 4.5/5.0.



Marked with lines to identify connection size:

- - marked with 2 lines.
- - marked with 3 lines.

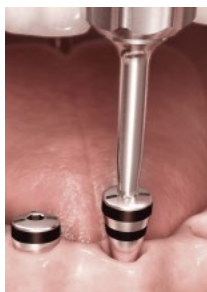
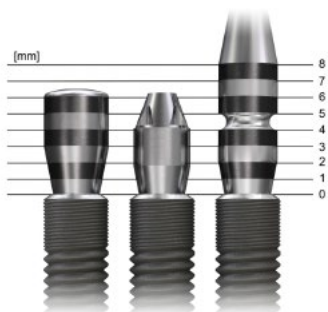

Depth Gauge instruction

Abutment Depth Gauge has two tips, one for Aqua and one for Lilac connection size. They are clearly marked with laser etched bands for measuring the mucosal height above the implant level in millimeters. The laser etched bands correspond to the Healing Abutment Uni as well as to the UniAbutment. The tips are inserted into the conical opening. The Depth Gauge should be sterilized by autoclaving after use.

Abutment selection

Select the appropriate final abutment using the Healing Abutment Uni. The bands correspond to millimeters as well as available UniAbutment heights.

Abutment Depth Gauge can also be used.



Abutment selection

The Astra Tech Implant System includes a wide range of abutments designed to successfully meet every clinical indication. In addition to simply connecting the crown to the implant, the abutments are designed to:

- Transfer forces to the implant, minimizing the risk of overload and fractures
- Establish and maintain healthy connective tissue and epithelial attachment
- Resolve dimensional and geometric discrepancies between crown and implant

Facts to consider when choosing an abutment:

- Indication — single tooth, partial bridge or a full fixed bridge
- Upper or lower jaw
- Implant angulations
- Marginal bone levels
- Soft tissue levels
- Occlusal and interproximal space
- Esthetic demands

Clinical application

- 20° UniAbutment is first choice for partial and full jaw screw-retained restorations.
- 45° UniAbutment is used when angulation between implants exceed 40° or when the intermaxillary height does not allow for the 20° UniAbutment.
- Angled Abutment is used when there is a need for altering the bridge screw insertion direction away from the axial direction of the implant.

Seating and tightening

The UniAbutment is seated in the implant, secured and tightened using the Torque Wrench.

Recommended torque:

- 15 Ncm
- 15 Ncm

The Angled Abutment is seated in the implant, secured and tightened with the abutment screw using the Hex Screwdriver or Torque Wrench.

Recommended torque:

- 20 Ncm
- 25 Ncm

Abutment selection

UniAbutment

Diameter 3.5 mm

Height 0.5-8 mm

Angled Abutment



Height 0.5-2 mm

Top cone height 5.1 mm



Select the appropriate abutment using the Healing Abutment Uni or the Abutment Depth Gauge.



Abutments for screw-retained restorations	Clinical application	Features and benefits
<p>20° UniAbutment Titanium</p> 	<ul style="list-style-type: none"> • Partial and fully edentulous situations • All positions in the mouth 	<ul style="list-style-type: none"> • Solid unit with a 20° tapered top cone • Different heights - 0.5-8 mm • Easy to handle with a self-guiding 11° tapered base - Conical Seal Design • The design offers outstanding flexibility in the clinical situation for implants placed in non-parallel situations by maintaining an axis of withdrawal for implants converging or diverging up to angles of 40°
<p>45° UniAbutment Titanium</p> 	<ul style="list-style-type: none"> • Partial and fully edentulous situations • All positions in the mouth <p>Note: It is contraindicated to use 45° UniAbutment as the only support for restorations on 3 implants or less. For these situations at least one support should be a 20° UniAbutment or Angled Abutment.</p>	<ul style="list-style-type: none"> • Solid unit with a 45° tapered top cone • Different heights 0.5-8 mm • Easy to handle with a self-guiding 11° tapered base - Conical Seal Design • Recommended when interocclusal space is limited and in non-parallel situations by maintaining an axis of withdrawal for implants converging or diverging up to angles of 90°
<p>Angled Abutment Titanium</p> 	<ul style="list-style-type: none"> • Partial and fully edentulous situations • All positions in the mouth 	<ul style="list-style-type: none"> • Two-piece component with an angled top cone allowing for a 20° angulation • Different heights 0.5-2 mm • Easy to handle with a self-guiding 11° tapered base - Conical Seal Design • 360° of restorative freedom or indexed version • Used when there is a need for altering the bridge screw insertion direction away from the axial direction of the implant



Select the appropriate UniAbutment according to bone level and soft tissue height. It is preferable for the restorative margin to be 1 mm below the soft tissue margin.



UniAbutment is available for connection sizes - 3.5/4.0 and 4.5/5.0.

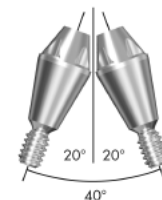

Using the 20° UniAbutment, implants that diverge or converge up to 40° can be managed.

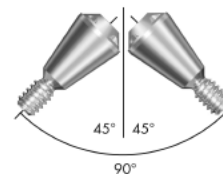

With the 45° UniAbutment, implants that diverge or converge up to 90° can be managed.

UniAbutment installation

Select the appropriate abutment using the Healing Abutment Uni. The bands correspond with millimeters as well as to the available UniAbutment heights. The Abutment Depth Gauge can also be used.

Components

- UniAbutment
- Angled Abutment
- Pre-mounted Carrier
- Hex Screwdriver
- Torque Wrench

Clinical procedure - UniAbutment installation

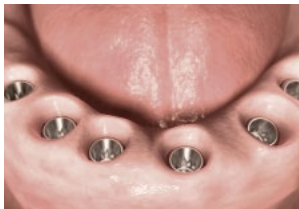

1.



4.



2.



5.

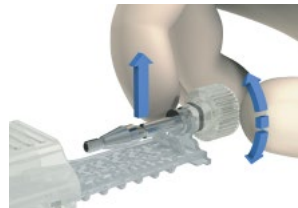

7.



9.



3.



6.



8.



10.

1. Remove the Healing Abutment Uni.

2. The label on the UniAbutment packaging has color-coding that matches the two different connection sizes:

● Implant diameters 3.5 and 4.0

● Implant diameters 4.5 and 5.0

3. Peel off the perforated part of the label and save it for documentation purposes.

4. Remove the cap and tear off the foil that protects the sterile compartment.

5. Slide out the pre-mounted UniAbutment on a sterile surgical area.

6. Push out the slider with the pre-mounted UniAbutment until it stops.

7. Rotate and lift out the UniAbutment using the plastic Delivery Cap.

8. Seat the self-guiding UniAbutment manually with the pre-mounted Carrier/Delivery Cap.

9. Recommended torque:

● 15 Ncm

● 15 Ncm

10. Release the carrier manually by unscrewing it with the Delivery Cap, or turn the Torque Wrench upside down and turn it counter-clockwise.

Angled Abutment installation

The Angled Abutment can be used in combination with the 20° UniAbutment and 45° UniAbutment.

Select the appropriate Angled Abutment using the Healing Abutment Uni. The bands correspond to millimeters. The Abutment Depth Gauge can also be used. The label on the Angled Abutment

packaging has a color-coding that matches the two different connection sizes:

- Implant diameter 3.5 and 4.0
- Implant diameter 4.5 and 5.0

Peel off the perforated part of the label and save it for documentation purposes.

Clinical procedure - Angled Abutment installation

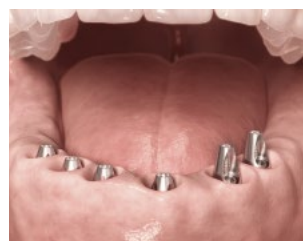
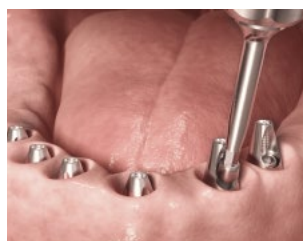

Remove the cap and tear off the foil that protects the sterile compartment. Slide out the plastic insert. Open the insert and take out the components on a sterile surgical area.

Install the Angled Abutment with the top cone positioned in the most optimal direction.

Secure the Angled Abutment with an Abutment Screw Angled using the Torque Wrench for final tightening. Recommended torque:

- 20 Ncm
- 25 Ncm

20° UniAbutment and Angled Abutment installed.

Healing Cap

Healing Caps are designed to provide optimal esthetic results and to protect the abutment and guide the soft tissue during the healing phase.

The Healing Cap for UniAbutment is a solid one-piece component and for the Angled Abutment it is a two-piece component consisting of a cap and a bridge screw.

Clinical application

- For 20° and 45° UniAbutment
- One version for Angled Abutment
- For intermediate use only
- Protects the abutment during healing

Features and benefits

- Soft tissue management
- Documented biocompatibility

Healing Cap for UniAbutment

- ProHeal Cap corresponds to the abutment pick-up design
- Different heights and diameters for maximized flexibility
- Friction fit to the Hex Screwdriver for easy handling

Healing Cap for Angled Abutment

- An indexing feature is provided for correct positioning

Seating and tightening

The ProHeal Cap is seated on the UniAbutment, secured and tightened using the Hex Screwdriver and light finger force or the Torque Wrench. Recommended torque is 5-10 Ncm.

The Healing Cap Angled is seated on the Angled Abutment, secured and tightened with the Bridge Screw Slot using the Slot Screwdriver, and light finger force or the Torque Wrench. Recommended torque is 5-10 Ncm.

Healing Cap Selection

20° and 45° UniAbutment
Diameters 4.3 and 5.5 mm
Short or long versions

Angled Abutment

Two piece component

Sterile

Material

Titanium



For the UniAbutment, the Healing Cap is available in two diameters, 4.3 and 5.5 mm.

Components

- ProHeal Cap
- Healing Cap, Angled
- Hex Screwdriver
- Torque Wrench



Clinical procedure – Healing Cap installation

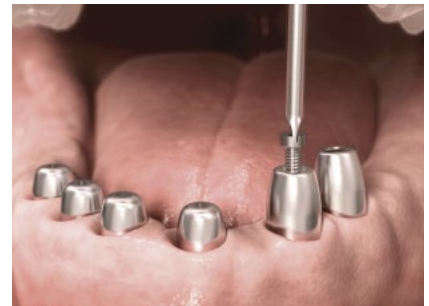

20° UniAbutment and Angled Abutment installed.

Connect the ProHeal Cap to the Hex Screwdriver and install the cap onto the UniAbutment using the Hex Screwdriver and light finger force or the Torque Wrench. Recommended torque is 5-10 Ncm.

Position the Healing Cap, Angled onto the Angled Abutment. Make sure the indexing feature in the cap is in the right position. Tighten the Bridge Screw, Slot using the Slot Screwdriver and light finger force or the Torque Wrench. Recommended torque is 5-10 Ncm.

Abutment-level impression

Abutments for abutment-level impression

- 20° UniAbutment
- 45° UniAbutment
- Angled Abutment

The UniAbutment Pick-ups are available in different diameters to follow the emergence profile of the ProHeal Cap. The pick-up for Angled Abutment is available in one version.

Impression components are designed to be able to transfer the clinical situation to the laboratory working model with exact replication.

Components

- Abutment Pick-up
- Abutment Transfer
- Hex Screwdriver

The Abutment Pick-up, available for UniAbutment and Angled Abutment, is a two-piece impression component, consisting of a sleeve and a guide pin.

The Abutment Transfer is a one-piece component.

Clinical application

- The pick-ups or transfers are used for abutment-level impressions
- Partial or full jaw impressions
- Suitable for all positions in the mouth

Features and benefits

The UniAbutment system offers the possibility of taking both closed-tray and open-tray impressions:

- Abutment Transfer – closed-tray impressions
- Abutment Pick-up – open-tray impressions

Clinical procedure – Abutment Pick-up



1.



3.

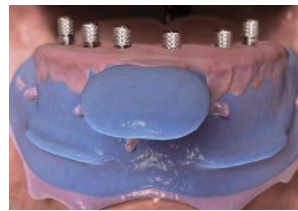

5.

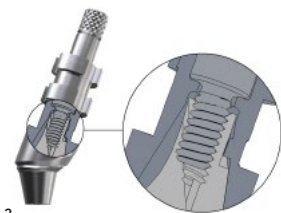

2.

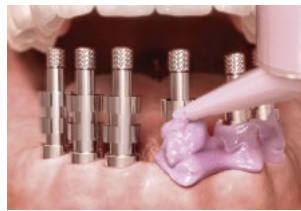

4.

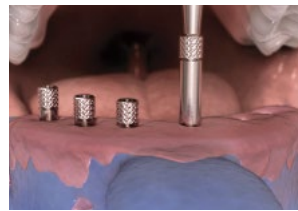

6.



7.

1. Select the appropriate Abutment Pick-up. Make sure the pick-up is in the correct position before tightening the abutment guide pin. Secure the guide pin with the Hex Screwdriver, using light finger force.

2. Angled Abutment has an indexing feature to ensure correct positioning.

3. Use a standard or customized impression tray. Make sure the guide pin can penetrate the tray without interfering with it. The prepared hole is covered with wax, which is penetrated by the guide pin during impression-taking.

4. Inject the elastomeric impression material around the abutment pick-up and into the impression tray.

5. Place the tray filled with impression material intraorally. Make sure the guide pin penetrates through the wax, covering the hole made in the tray.

6. Unscrew the guide pin after the impression material has set. Ensure that the guide pin is completely disengaged from the abutment before lifting the tray.

7. Check the impression for correct and stable retention of the abutment pick-up. Send the impression to the dental laboratory.

On Angled Abutment, the Abutment Pick-up is used for open-tray impressions. The Angled Abutment Pick-up is provided with an index feature for easy seating.

Seating and tightening

The Abutment Pick-up and Abutment Transfer are seated on the abutment and tightened using light finger force.



Component selection for UniAbutment

Abutment Pick-up

Diameters 4.3 mm and 5.5 mm

Abutment Transfer

Short and long version

Component selection for Angled Abutment

Abutment Pick-up

Diameter 5 mm

Material

Stainless steel

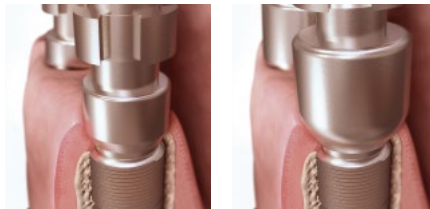

The Abutment Pick-up is available in two diameters: 4.3 and 5.5 mm.

Clinical procedure – Abutment Transfer

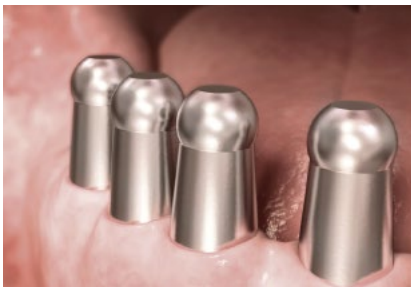

If there is a lack of vertical space, or a closed- tray technique is preferred, the UniAbutment Transfer can be used. The transfer is not available for the Angled Abutment.

1. Firmly screw the UniAbutment Transfer onto the UniAbutment. Position the tray with the elastomeric impression material over the UniAbutment Transfer. When the impression material has set, carefully remove the tray from the jaw.

2. Unscrew the UniAbutment Transfers from the abutments. To reposition the transfers in the impression, mount the transfer on the replica and use the replica as a handle during re-positioning.

Note: It is important to give the correct abutment information to the dental technician in order to select the correct abutment replica.

Abutment-level working model

Abutments for abutment-level impression:

- 20° UniAbutment
- 45° UniAbutment
- Angled Abutment

Impression components are designed to allow the precise transfer of the clinical situation to the laboratory working model.

Abutment Replica

The Abutment Replica replicates the critical dimensions of the abutment.

It allows for correct position and orientation of the abutment in the working model.

The correct replica is selected according to the installed abutment, and positioned and tightened into the impression component.

Abutment option	Abutment Replica
20° UniAbutment	Abutment Replica Uni 20°
45° UniAbutment	Abutment Replica Uni 45°
Angled Abutment	Abutment Replica Angled

Every step is carefully carried out to ensure a passive fit of the final screw-retained restoration.

Clinical application

The Abutment Replica is used to replicate the corresponding abutment.

Features and benefits

- Precise replication of the abutment position in the mouth
- Retention for stable position in the stone material

Replica selection



Abutment Replica replicates the abutment top cone; 45°, 20° and angled.

Material
Stainless steel



Summary

Full arch screw-retained restoration on four 20° UniAbutments and two Angled Abutments. The final bridge is a porcelain fused to metal restoration. Handling procedures are carefully followed to ensure a passive fit and an esthetically correct result.

Frode Øye
Oral Surgeon
SpesDent, Oslo, Norway

Knut Øverberg
Specialist in Prosthodontics
SpesDent, Oslo, Norway

Svein Thorstensen
Master Dental Technician
Dental Studio, Oslo, Norway

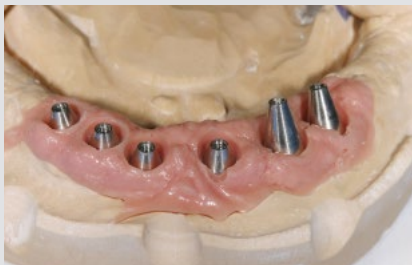

1. Abutment replica stone working model.



2. Wax-up of the framework using the Semi-Burnout Cylinder.



3. Metal framework ready for try-in.



4. Final metal-ceramic restoration.



5. Final screw-retained restoration is designed to ensure optimal hygienic performance.

Components

- Abutment Replica Uni
- Abutment Replica Angled
- Temporary Cylinder Uni
- Abutment Pick-up

Laboratory procedure

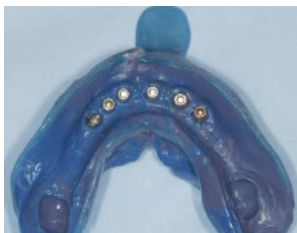

1.

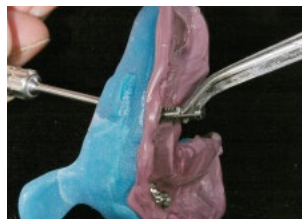

2.



3.



4.



5.



6.

Working model

The impression tray with elastomeric impression material and the Abutment Pick-up is received at the dental laboratory. It is important that the clinician gives the information about the abutment placed to the dental technician for correct replica selection.

1. Pull back the guide pin for proper placement of the abutment replica in the sleeve.

2. Seat the replica into the Abutment Pick-up and tighten the guide pin. To avoid disturbing the pick-up in the impression material, hold the replica with a firm grip with a pair of pliers when tightening the guide pin. The Abutment Replica Angled has an indexing feature to ensure correct positioning.

3. Check the impression for correct and stable retention of the abutment replicas.

Fabricate a soft tissue mask directly in the impression. Make sure the soft tissue material covers at least 2 mm of the Implant Replica. The soft tissue mask permits easy access for submucosal contouring and verification of component seating.

Pour high-quality stone material (type IV stone) into the impression tray. For correct expansion of the stone material, follow the manufacturer's instructions for use. It is important to use stone material which features smooth surfaces, excellent flow, low expansion and exact reproduction of the fine details.

4. A high-quality working model with a soft tissue mask and abutment replicas is fabricated.

5. Removable gingiva modeling material permits easy access for submucosal contouring and verification of component seating.

Registration of jaw relations

6. Occlusal wax rims fixed to an acrylic record base are used for the registrations needed. Incorporate two or three Temporary Cylinder Uni into the acrylic base, secured with guide pins.

Clinical procedure

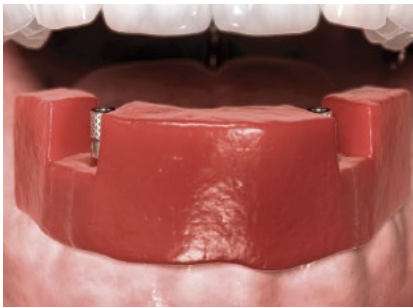

Laboratory procedure



Clinical procedure



Occlusal wax rim

Tighten the acrylic base to the abutments with the aid of two or three guide pins and the Temporary Cylinder Uni incorporated into the acrylic base. This creates a very stable situation during the registrations.

Well-accepted principles for function, esthetics and patient comfort are the basis for determining vertical dimension, free-way space, occlusal plane, centric relation, and arch form.

Teeth set-up

The wax rims are mounted on the model in the articulator and a teeth set-up for try-in is created.

Try-in of teeth set-up

Acrylic teeth set-up in wax is tried in the mouth. It is important that any adjustments needed to the set-up following this visit are not too extensive, to be able to fabricate the framework in the next procedure.

Cylinder options

The cylinder options are designed to meet the clinicians' demands on framework material and restorative options.

When working with implant restorations, treatment planning, teamwork, material selection and product options are crucial to ensuring a passive fit of the final restoration and long-term esthetic results.

Temporization

The Temporary Cylinder is a component which functions as a base for temporary screw-retained restorations on the abutment-level. By using a Temporary Cylinder, the soft tissue can be sculptured in an anatomically optimal shape, creating a good foundation for an esthetic final result.

The Temporary Cylinder can be handled chairside by the clinician or in the laboratory by the dental technician. In order to support optimal soft tissue sculpturing and to avoid unnecessary interference with the biological process, the design of the restoration should be as close to the final restoration as possible.

Cylinder Selection

Designed to be able to work with different material and techniques.

Cylinder base - Semi-Burnout Cylinder

Material

Non-oxidizing gold alloy:
Au 60%, Pt 24%, Pd 15%, Ir 1%

Melting range:

1400-1460°C/ 2552-2660°F

Coefficient of thermal linear expansion:

25-500°C 12.3 (10-6K-1)
25-600°C 12.7 (10-6K-1)

Cylinder base weight:

(20° or 45°): 0.3 grams

Plastic sleeve

Burnout temperature:
700°C/1292°F

Cylinder option for final restoration

The Semi-Burnout Cylinder is the optimal choice for the final restoration.

The Semi-Burnout Cylinder is a high precious gold cylinder used in the casting of multiple unit screw-retained restorations on the UniAbutment and the Angled Abutment. The Semi-Burnout Cylinder comprises the machined cylinder base with a pre-attached plastic burnout sleeve to support the wax-up.

Material selection

If another material is needed, the Burnout Cylinder offers complete



flexibility in selecting a material of choice. However, when working with conventional technique it is easier to design a passive fit framework using a pre-fabricated metal base than to use a burnout component.

Seating and tightening

The screw-retained restoration with the imbedded cylinder options are tightened using the Bridge Screw Slot or Hex. Temporary restoration is tightened using light finger force.

The final screw-retained restoration is seated and tightened using a bridge screw with a corresponding screwdriver or Torque Wrench. Recommended torque is 15 Ncm.



Cylinder used for screw-retained restorations	Clinical application	Features and benefits
<p>Temporary Cylinder Titanium</p> 	<ul style="list-style-type: none"> • Partial and full jaw temporary bridge restorations • Suitable for both the anterior and posterior regions 	<ul style="list-style-type: none"> • Used during the period of healing and sculpturing of the soft tissue prior to fabrication and installation of the final restoration
<p>Semi-Burnout Cylinder Non-oxidizing, high precious gold platinum alloy with a plastic wax-up sleeve</p> 	<ul style="list-style-type: none"> • Partial and full jaw bridge restorations • Suitable for both the anterior and posterior regions • When working with an alloy below the melting range of the cylinder base 	<ul style="list-style-type: none"> • Used for wax-up and cast-on technique • Pre-attached plastic sleeve for wax-up support
<p>Burnout Cylinder Burnout Plastic</p> 	<ul style="list-style-type: none"> • Partial and full jaw bridge restorations • Suitable for both the anterior and posterior regions 	<ul style="list-style-type: none"> • Complete flexibility to select a material of choice* <p>*It is more secure to design a passive fit framework using a pre-fabricated metal base than using a burnout component.</p>

Bridge Screw

Within the Astra Tech Implant System there are two Bridge Screw options – Bridge Screw Slot and Bridge Screw Hex.

The Bridge Screw Slot has a lower screw head, which is an advantage in situations of limited vertical height. The slot design allows the screw channel in the bridge restoration to be slightly angulated and still be possible to tighten with the Slot Screwdriver.

The Bridge Screw Hex has friction fit to the Hex Screwdriver which makes the prosthetic and laboratory procedures easy to handle.

Laboratory Bridge Screw

By using the Laboratory Bridge Screw you avoid the usage and wear of the clinical screw and hereby guaranteeing that a pristine screw is used in the clinical situation. A black slot and hex Laboratory Bridge Screw is available for UniAbutment and Angled Abutment.

Material
Titanium



Components

- Semi-Burnout Cylinder
- Bridge Screw Slot or Hex
- Slot or Hex Screwdriver
- Grinding Device
- Polishing Protector
- Laboratory Bridge Screw Slot or Hex

Laboratory procedure – UniAbutment/Angled Abutment



1.



2.



3.

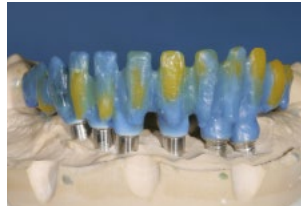

4.



5.



6.

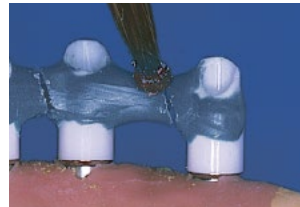

7.

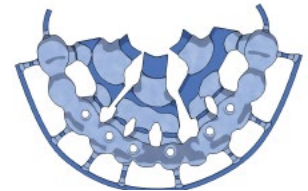

8.

Wax-up

1. Attach the Semi-Burnout Cylinder firmly to the abutment replica using a Laboratory Bridge Screw.

2. Cut back to appropriate dimensions on the Semi-Burnout Cylinder, Angled.

3. Cover the plastic sleeve on the Semi-Burnout Cylinder with wax. The layer of wax must have a sufficient thickness to avoid wrong coefficient of thermal expansion and a negative effect on porcelain firing.

Note: The metal base of the Semi-Burnout Cylinder, Angled must be covered with a wax layer all the way down to the restorative margin.

4. Wax-up the bridge framework. A metal framework is fabricated on the Semi-Burnout Cylinders using a regular wax-up technique.

5. Lingual aspect of the wax-up.

6. Cut the wax-up to ensure there are no interproximal connections between the different elements, and to confirm a passive fit of the wax-up.

7. Apply a resin material with low polymerization shrinkage to lute the segments of the wax-up together. Follow the manufacturer's instructions for use.

Preparation for investing

8. Prepare the wax-up for investing and casting procedures. Attach the runner bars. The separation of the runner bars depends on the size of the restoration. To achieve a horseshoe shape, separate into 3 parts.

Note: To avoid distortion, the completed casting should not have a button connecting the sprues after casting procedures.

Remove the wax-up from the working model and weigh the wax-up on a digital scale.

Invest, burnout and cast

Invest, burnout and cast the restoration. Follow the manufacturer's instructions for use.

Note: It is important to use an alloy compatible with the alloy in the cylinder base of the Semi-Burnout Cylinder.

The Semi-Burnout Cylinder absorbs a lot of heat during burnout and casting.

Make sure to compensate for this by:

- Increasing the time for the burnout and preheating procedures
- Raising the temperature slowly and increase the final burnout temperature by approximately 100°C/ 212°F

Devesting and framework verification

Carefully remove the bulk of the investment with devesting scissors. Devest the metal restoration using glass-beads.

Note: Do not blast in the cylinders. Remove residual investment material in the cylinders by using a pickling agent.



9.



10.



11.



12.



13.

Devesting and framework verification

9. Verify the metal framework. By following proper investing procedures carefully.

10. Make sure the screw channels are free from investment and nodules by using the Grinding Device.

11. The cylinders can be protected when blasting and grinding by using the Polishing Protector.

Checking the fit

12. Try-in and verify the framework on the working model. The restoration is seated on the abutment replicas with a passive fit. If preferred, a fit checker silicone can be used. Follow manufacturer's instructions for use.

13. Final metal framework. Send the metal framework to the clinic for try-in.

Components

- Bridge Screw Slot or Hex
- Slot or Hex Screwdriver

Clinical procedure – UniAbutment/Angled Abutment

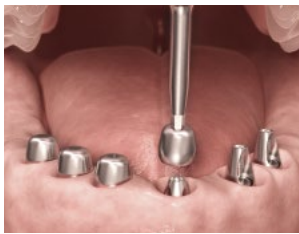

1.



3.



2.



4.

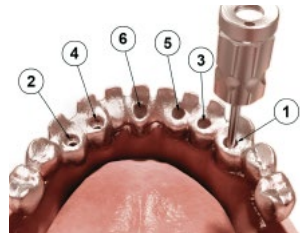

5.



6.

Try-in of metal framework

1. Remove the healing caps using the Hex Screwdriver.
2. Try-in the metal framework in the mouth to confirm a passive fit and an appropriate design for functional contacts and optimal soft-tissue situation.

3. Tighten the framework using the Bridge Screw Slot or Bridge Screw Hex.
4. When the framework is tried in the mouth, it must fit in a passive and impeccable manner. No tension should be present when tightening the framework to the abutments.

5. The insertion of the bridge screws can be done as follows (see figure).

Do not tighten any screws completely in one step. It is preferable to tighten each screw alternately. The patient is the most sensitive indicator of a poorly fitting framework. Even the smallest discrepancy between the framework and the abutments is experienced when the bridge screws are tightened.

If a framework is judged to be non-passive, cut it close to the problem area and take an index in a stiff material into the mouth. Solder or laser weld the framework pieces together and carry out a new try-in.

Note: Check the framework for porosities and discoloration.

6. Check dimensions, veneer support, and hygiene aspects and inspect occlusion and articulation.

Laboratory procedure



1.



3.



2.



4.

Porcelain build-up

1. Prepare the metal framework for porcelain build-up by cleaning, sandblasting and oxidation firing.
2. Build-up the porcelain according to the manufacturer's instructions for use.

3. Final screw-retained bridge restoration.
4. Lingual view of the screw access holes.

Clinical procedure



6.



5.



7.

Installation of final restoration

5. Check the final restoration for a passive fit. The base must be without porosities and show well polished convex surfaces. Pay careful attention to the relation between the bridge and the mucosa. A close functional and esthetic relation that ensures optimal hygienic performance should be the goal of the design.

Check the occlusion, articulation and protrusion and perform a meticulous intra-oral adjustment. Evaluate phonetic and esthetic performances.

Finally, provide the patient with thorough hygiene instructions and cleaning equipment.

Tightening the bridge screw

6. Tighten the bridge screws using a screwdriver or the Torque Wrench. Recommended torque is 15 Ncm.

Cover the bridge screw head with rubber or cotton before the screw entrance hole is filled with a suitable composite material.

7. Final restoration.

Prosthetic procedure – Care and maintenance / Final restoration



Care and maintenance

At check-up, examine for function, esthetics and phonetics.

Check for occlusion, articulation and protrusion and correct as needed.

Check for hygiene observance.

Often, the same hygiene guidelines apply as in the case of patients treated for periodontal disease.

1. Small interdental brushes, dental floss and a regular toothbrush are recommended to maintain a plaque-free environment.

It is advisable to check the patient on a regular basis to make sure function and hygiene are according to protocol.

The soft tissue close to the abutments is carefully examined to ensure a healthy soft tissue.

Final restoration

2. Healthy soft and hard tissue are prerequisites for true, long-term esthetic results.

Components

- Removal Tool
- Ratchet Wrench
- Torque Wrench
- Hex Screwdriver

Clinical procedure – Removal of UniAbutments with grooves

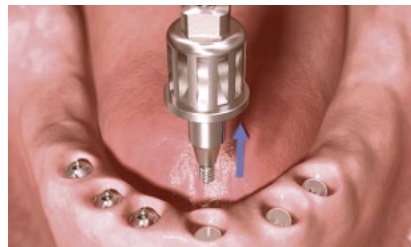
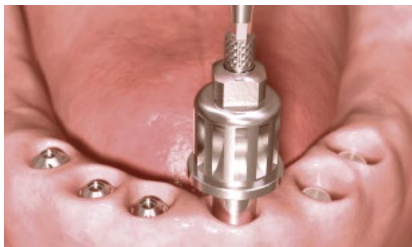
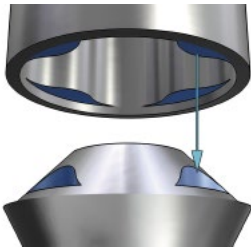

Removal of UniAbutments with grooves

1-2. Position the Removal Tool onto the UniAbutment and tighten the screw using the Hex Screwdriver.

3. Unscrew the abutment using the Torque Wrench/Ratchet Wrench by turning the wrench counter-clockwise.

4. Remove the abutment from the implant.

5. To remove the abutment from the Removal Tool, unscrew the screw, which will separate the parts.

Components

- Abutment Adapter
- Wrench
- Torque Wrench
- Ratchet Wrench

Clinical procedure – Retrieval of UniAbutment

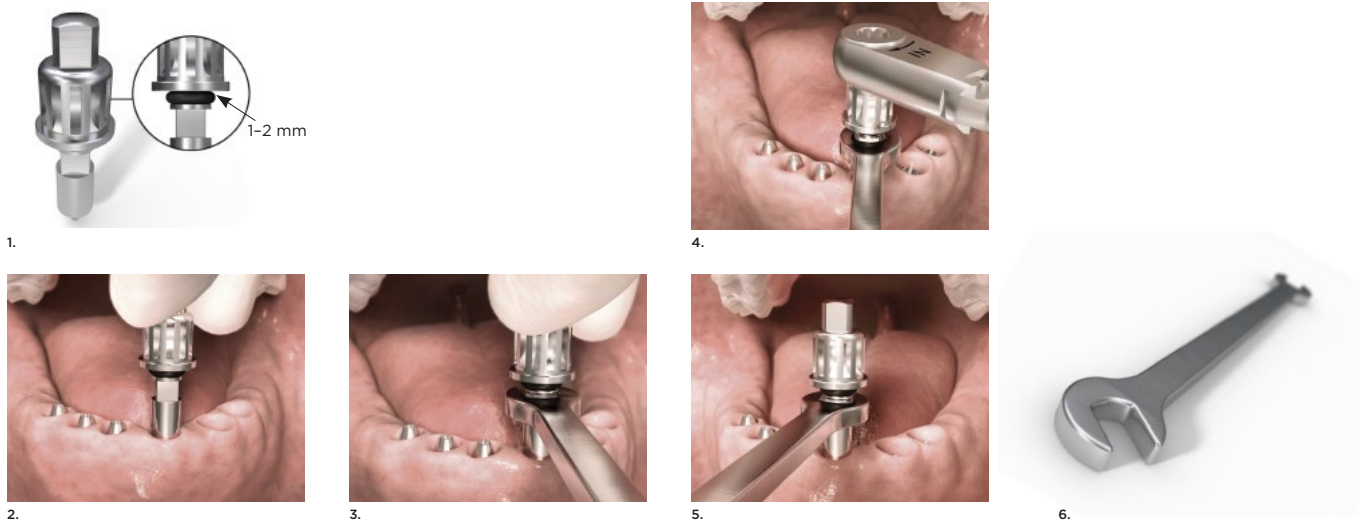

UniAbutment retrieval using Abutment Adapter

1. In the event that an UniAbutment needs to be retrieved, always use the Abutment Adapter. Check the gap of the adapter (1-2 mm). The lock nut should fit snugly against the O-ring.

Note: Do not compress the O-ring.

2. Mount the Abutment Adapter on the UniAbutment with finger light torque.

3. Hold the adapter head steady and tighten the lock nut counter-clockwise with the Wrench.

UniAbutment retrieval using an alternative method

4. If the standard procedure does not work, it is possible to use the Torque Wrench with the Abutment Adapter mounted.









Note: Keep the Torque Wrench steadily in place, in the clockwise position and tighten the lock nut counter-clockwise with the Wrench.

5. Release the abutment by turning the lock nut very slightly with a firm short movement of the Wrench. Allow the adapter head to follow the motion.

6. Use the Wrench together with the Abutment Adapter.

Alternative methods are explained in the Repair procedure manual.

Recommended tightening torque

Type of product		Torque - Ncm		
		X-Small	Small	Large
Cover Screw		● Manual*	● Manual*	● Manual*
Healing Abutment Healing Abutment Uni ProHeal Cap Healing Cap Angled		● Manual**	● Manual**	● Manual**
TempDesign™		● —	● 15	● 15
Temporary Abutment		● 15	● 15	● 15
20°/45° UniAbutment		● —	● 15	● 15
Bridge Screws		● —	● 15	● 15
Atlantis® abutments for Astra Tech Implant System® ZirDesign™ TiDesign™ CastDesign™ Angled Abutment		● 15***	● 20	● 20
Direct Abutment™ Ball Abutment Locator™ Abutment		● —	● 25	● 25

* Only light finger force (5-10 Ncm) using a manual screwdriver or contra angle preset at 25 rpm and 5-10 Ncm torque.

** Only light finger force (5-10 Ncm) using a manual screwdriver. Do not use a Ratchet Wrench or Torque Wrench.

*** **Note:** Available for TiDesign, Atlantis abutment - titanium and Atlantis abutment - Gold shaded.

Sterile packaging

The Healing Abutments, UniAbutments, Angled Abutments and Healing Caps are delivered sterile. The products are sterilized by irradiation and intended for single use only. The label on the package is color coded Aqua or Lilac to indicate the connection sizes. The package is comprised of a plastic container with a cap. There is a foil under the cap that serves as the sterile barrier.



- Implant diameter 3.5 and 4.0
- Implant diameter 4.5 and 5.0

Product	Material	Sterilization	Package
Healing Abutment Uni	Titanium	The product is sterilized by irradiation and intended for single use only.	The sterile plastic insert, inside the container, contains the Healing Abutment Uni.
20° UniAbutment 45° UniAbutment	Titanium	The product is sterilized by irradiation and intended for single use only.	In the container the UniAbutment is packed pre-mounted with a disposable carrier in stainless steel. The carrier also serves as an installation device, together with a plastic insertion head.
Angled Abutment	Titanium	The product is sterilized by irradiation and intended for single use only.	The sterile plastic insert, in the container, contains the Angled Abutment. The abutment is packed together with the Angled Abutment Screw.
ProHeal Cap	Titanium	The product is sterilized by irradiation and intended for single use only.	The sterile plastic insert, in the container, contains the ProHeal Cap.
Healing Cap, Angled	Titanium	The product is sterilized by irradiation and intended for single use only.	The sterile plastic insert, inside the container, contains the Healing Cap. The cap is packed together with a Bridge Screw Slot.

References supporting screw-retained restorations using Astra Tech Implant System®

Partial and full prostheses

D'haese J, Vervaeke S, Verbanck N, De Bruyn H. Clinical and radiographic outcome of implants placed using stereolithographic guided surgery: A prospective monocenter study. *Int J Oral Maxillofac Implants* 2013;28(1):205-15. [Abstract in PubMed](#)

Oxby G, Oxby F, Oxby J, Saltvik T, Nilsson P. Early loading of fluoridated implants placed in fresh extraction sockets and healed bone: A 3- to 5-year clinical and radiographic follow-up study of 39 consecutive patients. *Clin Implant Dent Relat Res* 2015;17(5):898-907. [Abstract in PubMed](#)

Yi SW, Ericsson I, Kim CK, Carlsson GE, Nilner K. Implant-supported fixed prostheses for the rehabilitation of periodontally compromised dentitions: A 3-year prospective clinical study. *Clin Implant Dent Relat Res* 2001;3(3):125-34. [Abstract in PubMed](#)

Fixed full prostheses

Arvidson K, Bystedt H, Frykholm A, von Konow L, Lothigius E. Five-year prospective follow-up report of the astra tech dental implant system in the treatment of edentulous mandibles. *Clin Oral Implants Res* 1998;9(4):225-34. [Abstract in PubMed](#)

Barbier L, Abeloos J, De Clercq C, Jacobs R. Peri-implant bone changes following tooth extraction, immediate placement and loading of implants in the edentulous maxilla. *Clin Oral Investig* 2012;16(4):1061-70. [Abstract in PubMed](#)

Cooper LF, Rahman A, Moriarty J, Chaffee N, Sacco D. Immediate mandibular rehabilitation with endosseous implants: Simultaneous extraction, implant placement, and loading. *Int J Oral Maxillofac Implants* 2002;17(4):517-25. [Abstract in PubMed](#)

Mertens C, Steveling HG, Stucke K, Pretzl B, Meyer-Baumer A. Fixed implant-retained rehabilitation of the edentulous maxilla: 11-year results of a prospective study. *Clin Implant Dent Relat Res* 2012;14(6):816-27. [Abstract in PubMed](#)

Murphy WM, Absi EG, Gregory MC, Williams KR. A prospective 5-year study of two cast framework alloys for fixed implant-supported mandibular prostheses. *Int J Prosthodont* 2002;15(2):133-8. [Abstract in PubMed](#)

Rasmusson L, Roos J, Bystedt H. A 10-year follow-up study of titanium dioxide-blasted implants. *Clin Implant Dent Relat Res* 2005;7(1):36-42. [Abstract in PubMed](#)

Vervaeke S, Collaert B, Cosyn J, De Bruyn H. A 9-year prospective case series using multivariate analyses to identify predictors of early and late peri-implant bone loss. *Clin Implant Dent Relat Res* 2016;18(1):30-9. [Abstract in PubMed](#)

Fixed partial prostheses

Balleri P, Ferrari M, Veltri M. One-year outcome of implants strategically placed in the retrocanine bone triangle. *Clin Implant Dent Relat Res* 2010;12(4):324-30. [Abstract in PubMed](#)

Cecchinato D, Bengazi F, Blasi G, et al. Bone level alterations at implants placed in the posterior segments of the dentition: Outcome of submerged/non-submerged healing. A 5-year multicenter, randomized, controlled clinical trial. *Clin Oral Implants Res* 2008;19(4):429-31. [Abstract in PubMed](#)

Gotfredsen K, Karlsson U. A prospective 5-year study of fixed partial prostheses supported by implants with machined and tio2-blasted surface. *J Prosthodont* 2001;10(1):2-7. [Abstract in PubMed](#)

Guljé F, Abrahamsson I, Chen S, et al. Implants of 6 mm vs. 11 mm lengths in the posterior maxilla and mandible: A 1-year multicenter randomized controlled trial. *Clin Oral Implants Res* 2013;24(12):1325-31. [Abstract in PubMed](#)

Koutouzis T, Wennstrom JL. Bone level changes at axial- and non-axial-positioned implants supporting fixed partial dentures. A 5-year retrospective longitudinal study. *Clin Oral Implants Res* 2007;18(5):585-90. [Abstract in PubMed](#)

Lee DW, Choi YS, Park KH, Kim CS, Moon IS. Effect of microthread on the maintenance of marginal bone level: A 3-year prospective study. *Clin Oral Implants Res* 2007;18(4):465-70. [Abstract in PubMed](#)

Wennström J, Zurdo J, Karlsson S, et al. Bone level change at implant-supported fixed partial dentures with and without cantilever extension after 5 years in function. *J Clin Periodontol* 2004;31(12):1077-83. [Abstract in PubMed](#)

Zhou J, Huang Q, Wang X, et al. Early loading of splinted implants in the posterior mandible: A prospective multicentre case series. *J Clin Periodontol* 2016;43(3):298-304. [Abstract in PubMed](#)

About Dentsply Sirona Implants

Dentsply Sirona Implants offers comprehensive solutions for all phases of implant therapy, including Ankylos®, Astra Tech Implant System® and Xive® implant lines, digital technologies, such as Atlantis® patient-specific solutions and Simplant® guided surgery, Symbios® regenerative solutions, and professional and business development programs, such as STEPPS™. Dentsply Sirona Implants creates value for dental professionals and allows for predictable and lasting implant treatment outcomes, resulting in enhanced quality of life for patients.

About Dentsply Sirona

Dentsply Sirona is the world's largest manufacturer of professional dental products and technologies, with a 130-year history of innovation and service to the dental industry and patients worldwide. Dentsply Sirona develops, manufactures, and markets a comprehensive solutions offering including dental and oral health products as well as other consumable medical devices under a strong portfolio of world class brands. As The Dental Solutions Company™, Dentsply Sirona's products provide innovative, high-quality and effective solutions to advance patient care and deliver better, safer and faster dentistry. Dentsply Sirona's global headquarters is located in York, Pennsylvania, and the international headquarters is based in Salzburg, Austria. The company's shares are listed in the United States on NASDAQ under the symbol XRAY.

Visit www.dentsplysirona.com for more information about Dentsply Sirona and its products.